

| | | | | |
|------|--------|------|-------|----------|
| Rev. | Modify | Date | Firma | Approved |
| | | | | |

| | | | | |
|------|--------|------|-------|----------|
| Rev. | Modify | Date | Firma | Approved |
| | | | | |

| | | | | |
|------|--------|------|--------|----------|
| Rev. | Modify | Date | Signed | Approved |
| | | | | |

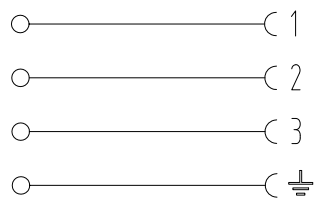
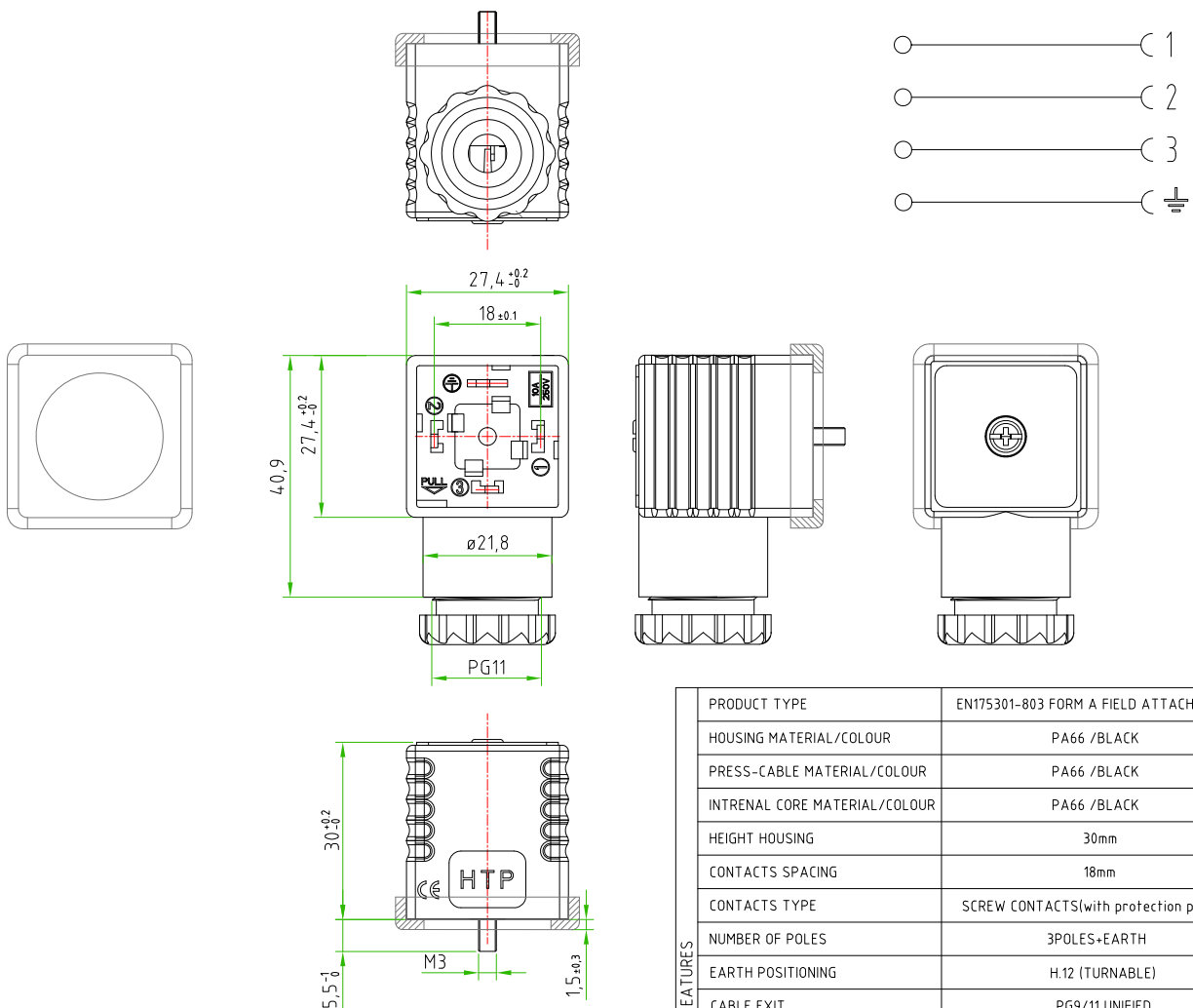

| CONNECTOR FEATURES | |
|-------------------------------|---------------------------------------|
| PRODUCT TYPE | EN175301-803 FORM A FIELD ATTACHABLE. |
| HOUSING MATERIAL/COLOUR | PA66 /BLACK |
| PRESS-CABLE MATERIAL/COLOUR | PA66 /BLACK |
| INTRINAL CORE MATERIAL/COLOUR | PA66 /BLACK |
| HEIGHT HOUSING | 30mm |
| CONTACTS SPACING | 18mm |
| CONTACTS TYPE | SCREW CONTACTS(with protection plate) |
| NUMBER OF POLES | 3POLES+EARTH |
| EARTH POSITIONING | H.12 (TURNABLE) |
| CABLE EXIT | PG9/11 UNIFIED |
| SUITABLE CABLE | FROM ø6mm TO ø10mm |
| MAX.CONDUCTOR SIZE | 1,5mm ² |
| PROTECTION CLASS | IP67 |
| CIRCUIT TYPE | WITHOUT ELECTRONIC |
| RATED VOLTAGE | 250V AC / 300V DC |
| CONNECTOR TEMPERATURE RANGE | from -40°C to +90°C |
| GASKET TYPE | PROFILED NBR |
| FIXING SCREW | M3X0,5 L=32,5mm |
| CONNECTOR WITH H.T.P. LOGO | |

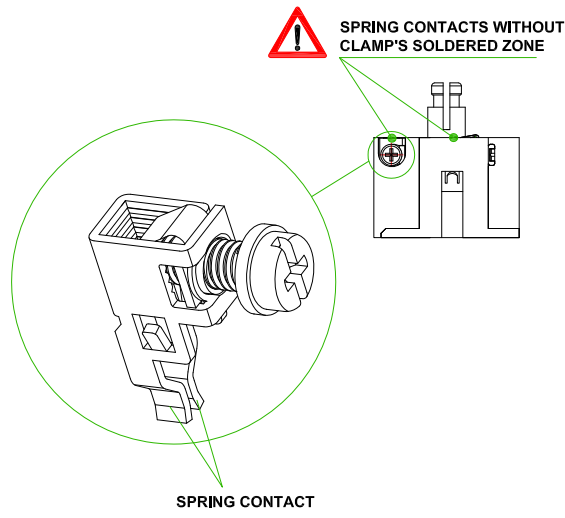

| | |
|------------------------|------|
| CUSTOMER APPROVAL | |
| SIGNATURE | DATE |
| | |
| PLEASE SIGN AND RETURN | |

| | | | | | | | | | | | |
|----------|-------------|------|------------|-----------|------|--------|----|----------------|-----------------------|------------|-----|
| Designer | SUGLIANI R. | Date | 2016-07-01 | Tolerance | ±0,2 | Units: | mm | Series | EN175301-803 (form A) | Drawing n. | 1/1 |
| Approved | CIMMINO L. | Date | 2016-07-01 | Scale | 1:1 | Size: | A4 | Customer code: | | | |



DESCRIPTION
 SQUARE CONNECTOR EN175301-803 FORM A, FIELD ATTACHABLE, 3P. +PE, WITHOUT ELECTRONIC, 250V AC / 300V DC, BLACK HOUSING, PG9/11 unified. CONNECTOR WITH H.T.P. LOGO.

H.T.P.PART NUMBER
 G1NU3000