

DATE	REV.	DESCRIPTION	NAME
02/03/2017	01	On the connector housing must be changed the silk print and the ATEX logo. On the seal on the plastic bag must be changed the silk print and the ATEX logo. See the drawing	ROBERTO SUGLIANI
07/08/2018	02	On the ATEX label and on the operating instructions must be added MADE IN CHINA.	ROBERTO SUGLIANI
21/09/2021	03	On the connector housing must be changed the silk print and the ATEX logo. On the label of the plastic bag must be changed the silk print and the ATEX logo. See the drawing	ROBERTO SUGLIANI

- — C 1
- — C 2
- — C 3
- — C 4

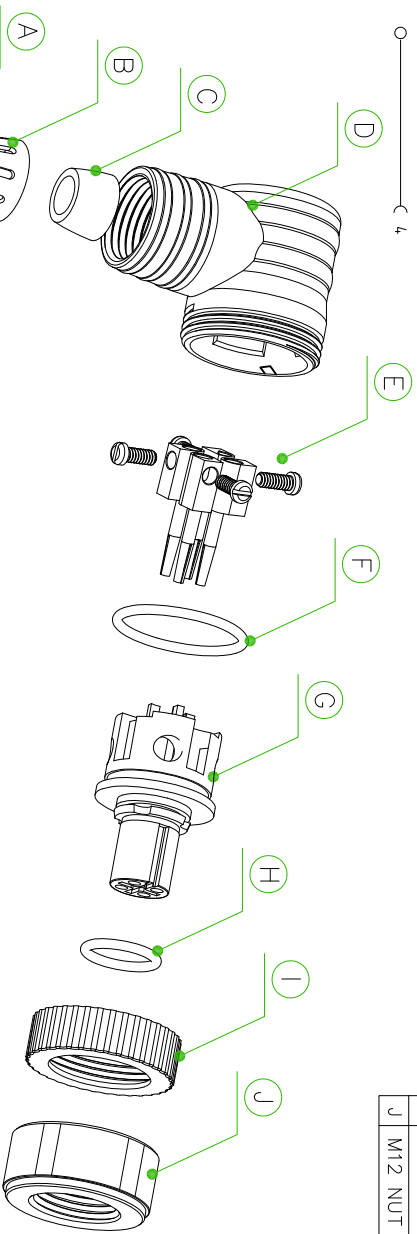

A	PRESS CABLE SCREW
B	LAMELLAE PRESS-CABLE SEAL
C	GASKET PRESS-CABLE SEAL
D	HOUSING BLACK
E	SCREW CONTACT GOLD PLATED
F	O-RING
G	INTERNAL CORE M12 A-CODED
H	O-RING
I	PLASTIC NUT FOR HOUSING
J	M12 NUT Brass-nickel plated (CuZnNi)

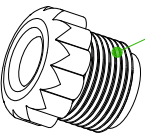

PACKAGING: REV. 03

SINGLY PACKED IN THE PLASTIC BAG
IN THE PLASTIC BAG MUST BE INSERTED THE
NEW OPERATING INSTRUCTION FOR CIRCULAR CONNECTORS.

H.T.P. PRODUCTION CODE

H.T.P. S.r.l.
I-24030 - BREMBATE DI SOPRA(BG)
CODE: 12FB4000-ATEX
M12 PLASTIC HOUSING
5#####
MAX VOLTAGE: 250V AC/DC
MAX CURRENT: 4A

YEAR: 20##
MADE IN CHINA

II 2G-Ex eb IIC T5 Gb
II 2D Ex tb IIIC T100°C Db IP65/67
TUV IT20ATEX037X

CE 0948

WHITE LABEL

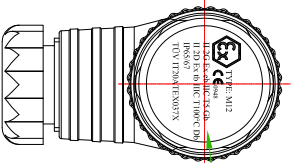
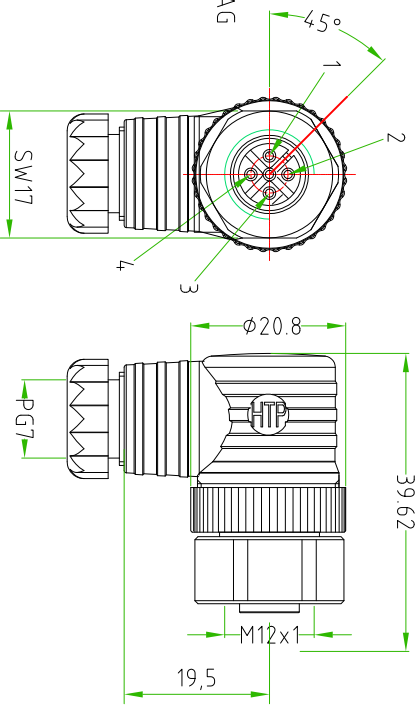

TYPE: M12
II 2G-Ex eb IIC T5 Gb
II 2D Ex tb IIIC T100°C Db
IP65/67
TUV IT20ATEX037X

PAV ATTENTION: REV. 03

CONNECTOR FEATURES

PRODUCT TYPE	M12 CIRCULAR CONNECTOR FIELD ATTACHABLE MAIN REFERENCE NORM ATEX2014/34/EU
CONNECTOR TYPE	ANGLED 90°
HOUSING MATERIAL/COLOR	PA66 3004G-30 (30%GF)/BLACK
PRESS-CABLE MATERIAL/COLOR	PA66 GM3004/BLACK
INTERNAL CORE MATERIAL/COLOR	PA66 GM3004/BLACK
M12 SW17 EXAGONAL COUPLING NUT MATERIAL	BRASS + NICKEL PLATED
CONTACTS TYPE	FEMALE SCREW CONTACTS
NUMBER OF POLES	4POLES
CABLE EXIT	PG7
MAX. CONDUCTOR SIZE	0.75mm ² (AWG18)
PROTECTION CLASS	IP65/67
RATED VOLTAGE	250V AC/DC
RATED CURRENT	4A
CREEPAGE AND CLEARANCE (MINIMUM DISTANCE BETWEEN CONTACTS EN-60079-7)	CREEPAGE: 2.6mm CLEARANCE: 2.1mm
CONNECTOR TEMPERATURE RANGE	from -40°C to +85°C
CONNECTOR WITH H.T.P. LOGO	



PACKAGING:
SINGLY PACKED IN PLASTIC BAG. ON EACH PLASTIC BAG MUST
BE APPLIED THE ATEX LABEL. IN EACH PLASTIC BAG MUST BE
INSERTED THE OPERATING INSTRUCTION SHEET.

TOLLERANZE	±0.2	DISIGNAZIONE	DATA	SCALA	DISIGNO
UDM	ANGULO	LORENZO CHINNO CONTROLLO	19.03.15	1:1	1/2
DESCRIZIONE	M12 FEMALE ANGLED 90° 4POLES, FIELD ATTACHABLE CONNECTOR MAIN REFERENCE NORM ATEX2014/34/EU		TIPO	M12	MATERIALE
H.T.P. HIGH TECH PRODUCTS			CODE	12FB4000-ATEX	

DATE	REV.	DESCRIPTION	NAME
02/03/2017	01	On the connector housing must be changed the silk print and the ATEX logo. On the label of the plastic bag must be changed the silk print and the ATEX logo. See the drawing	ROBERTO SUGLIANI
07/08/2018	02	On the ATEX label and on the operating instructions must be added MADE IN CHINA.	ROBERTO SUGLIANI
21/09/2021	03	On the connector housing must be changed the silk print and the ATEX logo. On the label of the plastic bag must be changed the silk print and the ATEX logo. See the drawing	ROBERTO SUGLIANI

FRONT

REV.03

BACK



H.T.P. High Tech Products S.R.L.
Via Lesina, 45
24030 Brembate di Sopra (BG) - Italy
Tel. +39 035 468200
Fax +39 035 468201
VAT# IT02828450157
www.htp.it - info@htp.it

EU TYPE DECLARATION OF CONFORMITY
DICHIAZIONE DI CONFORMITA' DEL TIPO

H.T.P. High Tech Products S.R.L.

Manufacturer's Name: **H.T.P. High Tech Products S.R.L.**
 Manufacturer's address: **Via Lesina 45 - 24030 Brembate di Sopra (BG) - Italy**
 Manufacturer's name: **H.T.P. High Tech Products S.R.L.**
 Manufacturer's address: **Via Lesina 45 - 24030 Brembate di Sopra (BG) - Italy**

This declaration of conformity is issued under the responsibility of the manufacturer.
La presente dichiarazione di conformità è rilasciata sotto la responsabilità esclusiva del fabbricante.

Product description: **M8 Field attachable junction device SERIES:M8 PLASTIC HOUSING**
 Description of the product: **M12 Field attachable Junction device SERIES:M12 PLASTIC HOUSING**
M12 Field attachable Junction device SERIES:M12 METAL HOUSING

In accordance with applicable regulations below
 Societ a la seguente Direttiva: **2014/34/EU - Aex**

Marking: **M12: I 2G Ex eb IIC T5 Gb I 2D Ex Ib IIC T100°C Db IP69/P67**
 Marcatura: **M8: I 2G Ex eb IIC T5 Gb IP69/57**

Certificate number edit by TDV SUD Ltd, notified Body number 0948: **TDV IT20ATEX037X**
 Numero certificato emesso da TDV SUD Ltd, organismo Notificato numero 0948:

Compliance with the essential health and safety requirements has been assured by compliance with:
 La conformit a dei requisiti essenziali di sicurezza e salute   assicurata dalla conformit a alle norme:
EN 60079-0:2018 - EN IEC 60079-7:2015/A1:2018 - EN 60079-31:2014

The products of the above declaration comply with the relevant legislation of harmonization of the Union
 I prodotti della dichiarazione di cui sopra sono conformi alla pertinente normativa di armonizzazione dell'Unione

NOME E COGNOME
Diego Lissana (C.F.O.)

MADE IN CHINA



H.T.P. High Tech Products S.R.L.
Via Lesina, 45
24030 Brembate di Sopra (BG) - Italy
Tel. +39 035 468200
Fax +39 035 468201
VAT# IT02828450157
www.htp.it - info@htp.it

EU TYPE DECLARATION OF CONFORMITY
DICHIAZIONE DI CONFORMITA' DEL TIPO

H.T.P. High Tech Products S.R.L.

Manufacturer's Name: **H.T.P. High Tech Products S.R.L.**
 Manufacturer's address: **Via Lesina 45 - 24030 Brembate di Sopra (BG) - Italy**
 Manufacturer's name: **H.T.P. High Tech Products S.R.L.**
 Manufacturer's address: **Via Lesina 45 - 24030 Brembate di Sopra (BG) - Italy**

This declaration of conformity is issued under the responsibility of the manufacturer.
La presente dichiarazione di conformit a   rilasciata sotto la responsabilit a esclusiva del fabbricante.

Product description: **M12 Female angled 90° 4poles, Field attachable Connector**

In accordance with applicable regulations below
 Societ a la seguente Direttiva: **2014/34/EU - ATEX**

Marking: **M12: I 2G Ex eb IIC T5 Gb I 2D Ex Ib IIC T100°C Db IP69/P67**
 Marcatura: **M8: I 2G Ex eb IIC T5 Gb IP69/57**

Certificate number edit by TDV SUD Ltd, notified Body number 0948: **TDV IT20ATEX037X**
 Numero certificato emesso da TDV SUD Ltd, organismo Notificato numero 0948:

Compliance with the essential health and safety requirements has been assured by compliance with:
 La conformit a dei requisiti essenziali di sicurezza e salute   assicurata dalla conformit a alle norme:
EN 60079-0:2018 - EN IEC 60079-7:2015/A1:2018 - EN 60079-31:2014

The products of the above declaration comply with the relevant legislation of harmonization of the Union
 I prodotti della dichiarazione di cui sopra sono conformi alla pertinente normativa di armonizzazione dell'Unione

NOME E COGNOME
Diego Lissana (C.F.O.)

MADE IN CHINA

TOLLERANZE	DISGNAZIONE	DATA	SCALA	DESIGNO
UDH	ANGLO	LORENZO CHINNO	19.03.15	1:1
	CONTROLLO			
DESCRIZIONE	M12 FEMALE ANGLED 90° 4POLES, FIELD ATTACHABLE CONNECTOR MAIN REFERENCE NORM A TEX2014/34/EU	TIPO	M12	MATERIALE
		CODE	12FB4.000 - A TEX	